

Horizon

CRF-362

Creaser and Folder

Creasing and folding in one pass.



Creasing and folding for heavier sheets in Avoid cracking of digitally-printed stocks

Sharp Creasing and Folding

Suitable for creasing covers, restaurant menus, shop cards, invitation cards and laminated sheets. The impact creaser avoids cracking on digitally-printed applications.

Preparing Perfect Bound Book Covers

High quality creasing helps to prepare high quality perfect bound book covers. Spine, hinge and flap creases can be properly produced by selecting up or down creasing.

High Quality Folding

Two fold knives are equipped for high quality folding, even on heavy stocks. 6 different folding patterns can be set up simply by using the icon based touch screen.

Quick and Easy Operation

Quick and easy set-up and operation can be performed through the newly equipped high resolution color touch screen.

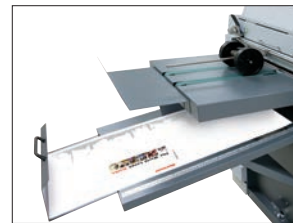

When operated without folding, the creaser can process 400 gsm for heavier stocks. (The stopper for long sheets is necessary.)

1 Touch Panel

Newly equipped high resolution touchscreen provides intuitive operation. Changeovers including fold pattern, creasing number and up / down crease selection can be done easily at this screen. Up to 200 jobs can be stored in memory for easy recall.



3 Sheet Registration

Sheets align to the register guide to ensure straight feeding for accurate creasing and folding. Sheet skew can be adjusted by changing the transport roller pressure on the registration guide.



2 Reliable Sheet Feeding

Uniquely designed suction belt feeding system enables stable feeding performance even with heavier sheets. An ultrasonic sensor ensures miss or double detection regardless of the print image or thickness of sheets.



4 Quality Creasing

Up to 10 creasing lines can be performed in one pass. Creasing depth can be adjusted. Up and down creasing are performed in one pass. Creasing positions can be adjusted in increments of 0.1 mm / 0.004"



n one pass.

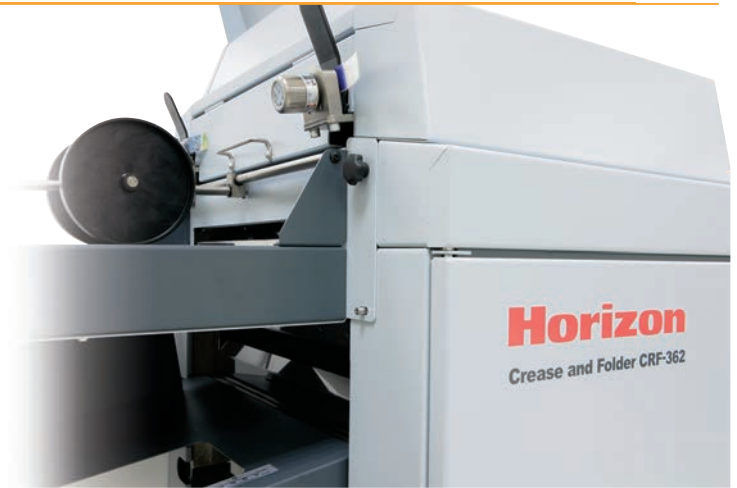

The support table for longer sheets is used when the sheet length is 650 mm / 25.59" or longer. The maximum sheet length which can be loaded is 865 mm / 34.00".

Sheet Flow

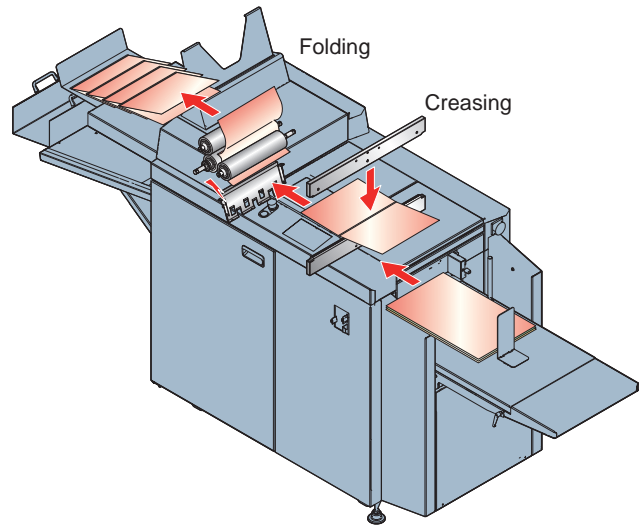

■ Creasing



The impact creaser avoids cracking on digitally-printed applications. When operated with creasing only, the creaser can process 400 gsm for heavy stocks.

5 Wide Variety of Folding

The large-diameter fold rollers are equipped for heavier stocks. Folding patterns include parallel fold, short fold, letter fold, double parallel fold, accordion fold, and open gate fold.



■ Folding Patterns

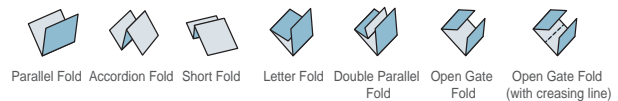

■ Covers for Perfect Binding (Creasing Patterns)

A wide variety of covers for perfect binding can be produced.

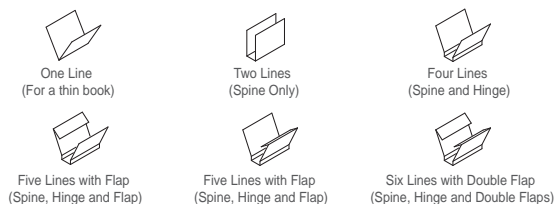

6 Dual Delivery

Folded jobs are delivered to the upper conveyor and neatly stacked for easy job handling. Flat creased jobs are delivered to the lower tray.

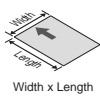

CRF-362 Specifications	
Feeding Mechanism	Air Suction Feed Belt
Sheet Size	 Max. 364 x 865 mm / 14.33" x 34.00" Min. 105 x 180 mm / 4.14" x 7.09"
Sheet Weight Range	Normal Paper : 80 to 350 gsm (with Folding) 80 to 400 gsm (without Folding) Coated Paper : 105 to 350 gsm (with Folding) 105 to 400 gsm (without Folding) Laminated Paper : 0.2 to 0.4 mm (with Folding) 0.2 to 0.5 mm (without Folding)
Feeder Pile Height	150 mm / 5.90"
Creasing Mechanism	One set of positive and negative (0.8 mm / 0.03", standard equipment)
Number of Creasing Lines	Max. 10 creasing lines
Production Speed	5,000 sheets/hr (A4 / one creasing line and fold)
Voltage / Frequency	Single Phase 200 to 240 V, 50 / 60 Hz
Machine Dimensions	W2,697 x D701 x H1,430 mm / W106.2" x D27.6" x H56.3"
Machine Weight	345 kg / 760.0 lb

Option

■ **Creasing Unit**
 Creasing units for different widths of creasing lines are available.

The following creasing units are available as options:

- Positive creasing unit for 0.5 mm / 0.020" (thin)
- Positive and negative creasing units for 1.3 mm / 0.512" (thick) and 2.0 mm / 0.079" (thick)



Machine Dimensions and Installation Space Unit : mm (inch)

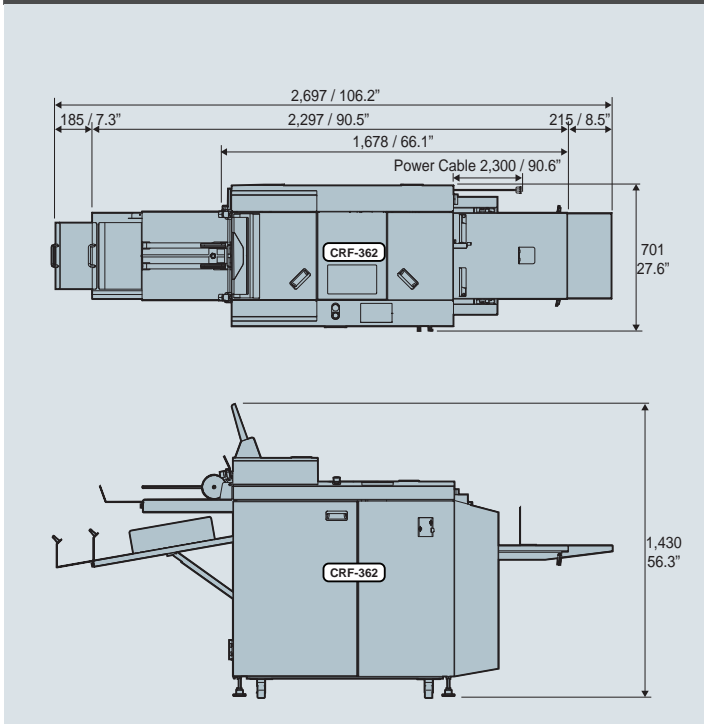

*The machine design and specifications are subject to change without any notice.

*The machine design and specifications are subject to change without any notice.